



# **Park Model**

# **Owners and Installation Manual**

# Congratulations on your purchase of an Athens Park Home!

Your new Athens Park Home is a “far above minimum” dwelling and deserves much better than minimum installation. For instance your new park model has R-22 insulation in the roof and R-11 in the sides and floor; the industry minimum is R-5. It can weigh twice as much as some other units the same size. We offer fiber cement siding with a 50 year transferable warranty on our park models except some cabins that feature cedar or spruce log siding. The fiber cement siding is not standard by any means on the average RV or park model. There are many other features, which your retailer has pointed out to you, that clearly demonstrate that you have purchased a superior park model. So it is only fitting that you should provide it a superior installation as well!

This is how it is done:

## 1. Is the lot well drained?

Water must not accumulate around or under your park model. Providing proper grading and drainage so that all water is minimized in the surrounding area within 10 feet from the structure will solve 90% of all potential foundation problems.

## 2. Is the site properly prepared?

Besides drainage, you need a firm spot to support your park model. All organic matter such as grass and topsoil must be removed and any needed fill must be properly compacted. The importance of this will be clearer as we go through the steps of installation.

## 3. What do I use to hold up my park model?

You have choices: many people use metal jack stands, some use cement blocks and there are other aftermarket devices that use a cement pedestal with a jack stand type head. Any of the above are fine as long as you do not exceed the working load that they are certified to hold. Loose stacked cement blocks can hold 8,000 lbs. on a single stack and 16,000 lbs. on a double stack (Refer to Picture 1). Manufactured piers usually have their ratings stamped on them and the tops should be of the type that clamp to the beam under the park model. All these are types of piers and their height should be kept to a minimum, but must be high enough to keep the wood floor framing at least 18 inches from the soil under the park model so it won't be damaged by ground moisture.

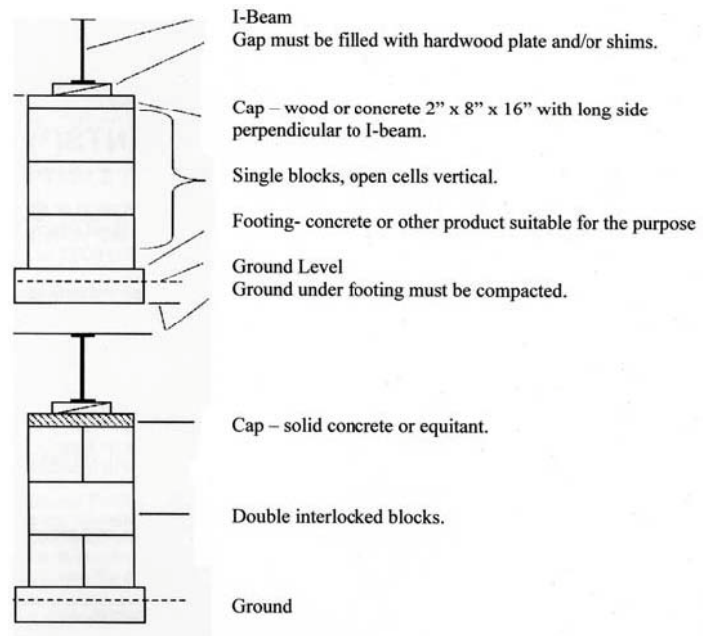

Picture 1

4. **What holds up the piers?** Every pier, cement block or otherwise, needs a footing to transfer the weight to the ground. The minimum size footing for your Athens Park model is 16" X 16" and thick enough not to crack under the load. Usually 2, 4" solid concrete blocks are good enough, (see picture 1 again) But ABS pads are alright too.
5. **How far apart do I place the footings?** Because an Athens Park Home weighs approximately 675 pounds per running foot under each I-beam, 99% of the time you want to space the piers about 6 feet apart and start no more than 2 feet from the ends of each beam with not less than 16" X 16" footings under them. In the very unlikely event you have settling, you could use bigger footings or put more of them in closer together. This only occurs on very soft ground, but more footings on the ground will fix the problem. Of course a concrete slab is the biggest footing you can get. It is a great option, but very rarely needed strictly for support. Any footing with water around it will settle and that is one of the reasons we graded the lot in step 1.

**Note:** At 675 pounds per foot, you will be holding 4,050 lbs. at six feet, if your piers are not rated for this load, then get bigger piers or put them closer together. Most will be OK, but better check anyway.

**Note:** If your park model is in a very cold part of the nation where the ground might freeze under the footings, then you need to have the bottom of the footings below the frost line if you want to prevent shifting of the park model in the winter.

6. **OK, all this holds my park model up, what holds it down?**  
Athens Park Homes has installed 3 anchor straps per side on every park model we build and we strongly recommend that you use them in conjunction with an extra strap from each anchor to the top of the nearest frame (See picture 2). You need to use the largest class anchor suitable for the type of soil you have. The anchor manufacturer will have the requirements and specifications, do what they say. Athens Park Homes also recommends that this work be done by an experienced worker in the business of anchoring homes.

Picture 2

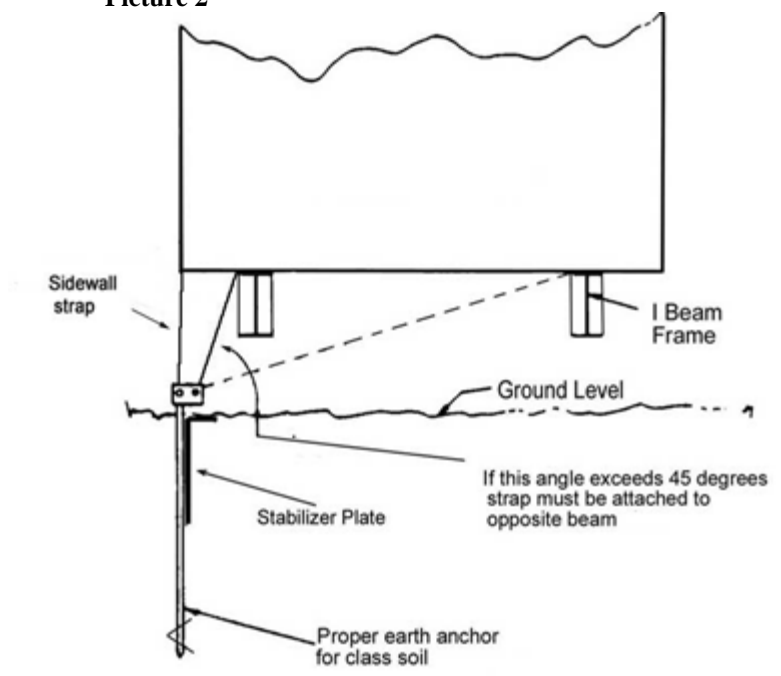

7. **Last step; put the plastic down on the ground.** This may seem strange, but it will greatly add to the longevity and comfort of your park model. Even well drained ground will still contain some moisture and that moisture will evaporate up into the park model if it doesn't have something to stop it, that something is called a vapor barrier and it is simple to do. Use at least 6 mil polyethylene plastic with all seams overlapped by at least 1 foot. You can put it down before you put the footings on the ground or you just cut out around the piers. Either way is OK, but when you cut around the piers try to make it a snug fit.

Do these 7 steps and your Athens Park Model will be far above average safe and solid, just like you and your family deserve.

## What about the Appearance of my Park Model?

Of course you want your new Athens Park Home to look great and nothing improves the appearance of a park model like skirting. There are a few things about ground enclosures (skirting) that you need to know. When you close up the space beneath the park model you create a separate environment under there and if it is not done properly it can create serious problems!

1. **What is the first thing I do?** Make sure you do not tightly enclose areas underneath the park model that allow water to come through, i.e. decks. If you do want to close off the area under a deck then be sure that you separate the deck area from the heated area under the park model with some sort of a vapor barrier. 6 mil plastic will do if you attach it firmly to the bottom of the park model where the living area stops and the deck/porch begins. Make sure that the water that may run into and through your decks will drain out from under the park model. This is another one of the reasons we grade the lot first.
2. **Make sure there is plenty of ventilation available.** The formula for proper ventilation for your park model, after the vapor barrier is down, is 1:150. This means that for every 150 square feet under the park model you enclose, you must have at least one square foot of ventilation in the skirting equally spaced around the park model. Skirting comes in sheets and is cut to fit, some sheets are vented and some are not, so just put up all vented panels and you don't even have to figure all this out. You can't put too much venting under a park model.
3. **Why is this so important?** It has to do with evaporating water under the park model and its ability to travel into the park model. If it is wetter under your park model than it is inside your park model, then the water will migrate into the park model and do severe damage to all the wood and/or drywall. Actual structural damage can occur in only a few years. Unfortunately, the better the park model is built, the bigger the problem can be. This is because the structure is so tightly built that air can't leak in and out of the park model. This is a very good thing for heating and air conditioning, but you must pay attention to moisture buildup and not all of it comes from the ground. Cooking without a fan on or taking a shower without the bath vent running can also add to the humidity. Running a clothes dryer without the vent ducted to beyond the perimeter walls will quickly cause problems. The test is when the windows "steam up" you have too much water vapor in the park model, open a few windows for a few moments and dry out the air in the park model. Then figure out what is making the humidity and correct the problem.

# Utilities

Your new park model has all the utilities that you probably have had in any home you have ever lived in and all the same rules apply. Don't turn on the electric hot water heater when it is empty! (The elements melt in 5 seconds) Don't put bigger breakers in the panel box than it is rated for and don't put things in front of the panel box so you can't get to it if you need to. You can have 50 amp services or you may have 100 amp services, it depends on the number and type of appliances that use electricity. The more gas appliances you get, the less electricity you need, so the size service you have depends on what was ordered in the park model.

Depending on what your park model has, here are some guidelines for utilities:

## 1. **Water**

The maximum water pressure you can connect your park model to is **80 PSI**. If the water pressure coming to the park model is more than that, install a pressure reducing valve and make sure it is set for less than 80psi. The pipes in your park model are protected from freezing as long as the park model is heated, but the supply pipe coming to your park model probably is not. You may need to insulate and install a heat tape on the incoming line if your park model is located where it freezes. Follow the directions that come with the UL approved heat tape exactly.

## 2. **Sewer**

Sewer pipe needs to drop in the direction of the outbound flow so that gravity will take the sewage away. This drop is measured in how much it lowers in one foot. The correct drop or "fall" for your park model is  $\frac{1}{4}$  inch for every foot of pipe. So, in four feet it will have dropped one inch. This drop of  $\frac{1}{4}$  inch per foot is important because if it is not this much, it will not flow right, and it will stop up the pipe. Strangely, if the pipe has much more than the  $\frac{1}{4}$  inch per foot fall, the liquid will run faster than "other" material in the pipe and that will stop it up too. Anything that is greater than a  $\frac{1}{4}$  inch per foot fall should be a vertical drop. Use a little care and it will be fine.

## 3. **Heat**

Your heat will be either gas or electric and each type of furnace will come with a book of directions and a warranty card. Read and understand the books and send in the card. Do not cover the floor registers with rugs or furniture. It could cause the furnace to malfunction and it will certainly affect the heating and A/C in the room.

Note: If your park model is located above 5000 feet in altitude you must have the furnace "de-rated" or it will shoot up. Any furnace professional in that area knows what to do.

## 4. **Air Conditioning**

In an Athens Park Home you have two choices for air. One is a built in system and the other is an outside self-contained unit. The self-contained unit has a special hookup under the park model for pulling in the air of the park model and sending it back to the ductwork. Make sure, if you decide on the outside unit, that you have the right size for the park model. Too small will not do the job, and too big will cause condensation in the park model structure resulting in costly damage. The size of your unit must be calculated by a competent professional for your park model and location.

## **Special Attention must be paid to the following if you have any gas appliances.**

### **Warning:**

LP-Gas cylinders shall not be placed or stored inside the vehicle. LP-Gas cylinders are equipped with safety devices that relieve excessive pressure by discharging gas to the atmosphere.

### **FAILURE TO COMPLY COULD RESULT IN DEATH OR SERIOUS INJURY.**

The following warning label has been located in the cooking area to remind the user to provide a supply of fresh air for combustion:

### **WARNING: IT IS NOT SAFE TO USE COOKING APPLIANCES FOR COMFORT HEATING.**

Cooking appliances need fresh air for safe operation. Before operation:

1. Open overhead vent or turn on exhaust fan, and
2. Open window

### **FAILURE TO COMPLY COULD RESULT IN DEATH OR SERIOUS INJURY**

Unlike homes, the amount of oxygen supply is limited due to the size of the recreational park trailer, and proper ventilation when using the cooking appliance(s) will avoid dangers of asphyxiation. It is especially important that cooking appliances not be used for comfort heating as the danger of asphyxiation is greater when the appliance is used for long periods of time.

A warning label has been located near the LP-Gas container location. This label reads:

### **WARNING: DO NOT FILL LP-GAS CONTAINER (S) TO MORE THAN 80 PERCENT OF CAPACITY FAILURE TO COMPLY COULD RESULT IN FIRE OR PERSONAL INJURY**

Overfilling the LP-Gas container can result in uncontrolled gas flow which can cause fire or explosion. A properly filled container will contain approximately 80 percent of its volume as liquid LP-Gas.

Warning: Portable fuel-burning equipment, including wood and charcoal grills and stoves, shall not be used inside the recreational park trailer. The use of this equipment inside the recreational park trailer can cause fires or asphyxiation.

Warning: Do not to bring or store LP-Gas containers, gasoline, or other flammable liquids inside the recreational park trailer because a fire or explosion can result.

The following warning label has been placed in the vehicle near the range area:

## **WARNING: IF YOU SMELL GAS:**

1. Extinguish any open flames, pilot lights, and all smoking materials.
2. Do not touch electrical switches.
3. Shut off the gas supply at the cylinder valve(s) or gas supply connection.
4. Open doors and other ventilating openings.
5. Leave the area until odor clears.
6. Have the gas system checked and leakage source corrected before using again

**FAILURE TO COMPLY COULD RESULT IN FIRE OR PERSONAL INJURY**

LP-Gas regulators must always be installed with the regulator vent facing downward. Regulators that are not in compartments have been equipped with a protective cover. Make sure the regulator vent faces downward and the cover is kept in place to minimize vent blockage which could result in excessive gas pressure causing fire or explosion.

## **Care and Maintenance of your Park model**

### **Exterior:**

#### **1. If I have Hardi siding what do I need to do?**

Not much really, when it gets dirty this product needs cleaning with ordinary soap and water and that is about it. It can be painted if you like, but the material itself is extremely durable. Its major ingredient is cement and there is just not much that can happen to it unless you hit it hard with a hammer or a large rock and break it. It has a 25 year warranty!

#### **2. What if I have wood siding or log style siding?**

As with any other product made from natural wood, it needs some care occasionally. If you use a high pressure washer on wood you could damage it if you don't know what you are doing, soap, water and a broom is safer. The log style siding should be sealed when it starts to look dry and faded. Any quality wood sealer, such as Thompson's Waterseal will do. Follow the directions on the container. It is fairly easy to apply and it doesn't take very long.

#### **3. What about the roof?**

Athens Park Homes uses two styles of roof, one is regular shingles and the other is a raised seam metal roof. Sometimes a few shingles can blow off if a storm is bad enough, so you should check after an event and repair them if necessary. The flashing around penetrations (vent pipes, stacks etc.) in the roof are sealed and flashed, but they can be affected by high wind as well, so check them as needed. Shingle roofs also have shipping strips at the hitch end of the park model so the shingles will not be damaged in transit. These need to be removed and sealed under each shingle that had a fastener through it. Metal roofs can be very slippery and will bend if too much weight is applied in an unsupported area (between rafters). In the unlikely event you have a problem with a metal roof; you should contact your Athens Park Homes retailer or a person familiar with these roofing materials

**Interior:**

Do not use abrasive cleaners such as Comet or Ajax on fiberglass surfaces such as tubs or sinks. It will destroy the finish over time. Use only products made for the surface you are cleaning.

Wood surfaces such as cabinets or paneling can be cleaned with any good furniture cleaner and polish.

On painted surfaces care should be taken to only wipe down the area to clean it. Excessive scrubbing can damage painted drywall surfaces.

## Conclusion

Following these simple directions and the included pamphlets that come with all appliances, should lead to a long and trouble free enjoyment of your new park model. Please pay particular attention to the first part of these instructions. Nearly all the major park model problems people ever have come from a faulty set-up and/or, the lack of proper site preparation. Having fresh air and no water under the park model will add immeasurably to your personal comfort and enjoyment as well as to the longevity of the park model.

You made a very good choice when you picked an Athens Park Home and these simple steps will help keep it that way.

Congratulations again and enjoy your new investment.

Here is our contact information:

**Champion Home Builders, Inc.**

**DBA: Athens Park Homes**

**3401 W. Corsicana St.**

**Athens, TX 75751**

**Phone- 903- 677- 0108**

**Fax-903- 677- 0118**

**[www.athensparkhomes.com](http://www.athensparkhomes.com)**

